

Dimensions

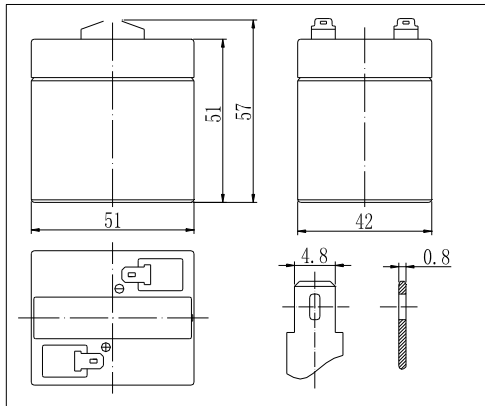

The Relationship for Open Circuit Voltage and Residual Capacity (25°C)

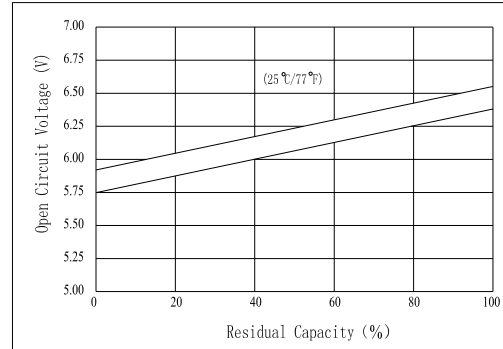

Specifications

Nominal Voltage		6 V
Capacity(20HR, 25°C)		1 Ah
Dimension	Length	51mm (2.01inch)
	Width	42mm (1.65inch)
	Height	51mm (2.01inch)
	Total Height	57mm (2.24inch)
Approx. Weight		0.26kg (0.57lbs)
Internal resistance (Fully charged, 25°C)		Approx. 54m Ω
Capacity affected by temperature (20HR)	40°C	102%
	25°C	100%
	0°C	85%
	-15°C	65%
Self-discharge (25°C)	3 month	Remaining Capacity: 91%
	6 month	Remaining Capacity: 82%
	12 month	Remaining Capacity: 65%
Nominal operating temperature		25°C ±3°C (77°F ±5°F)
Operating temperature range		-15°C ~50°C (5°F ~122°F)
Float charging voltage(25°C)		6.80 to 6.90V
Cyclic charging voltage(25°C)		7.25 to 7.45V
Maximum charging current		0.3A
Terminal material		Copper
Maximum discharge current		15A(5 sec.)

Charging Characteristics(25°C)

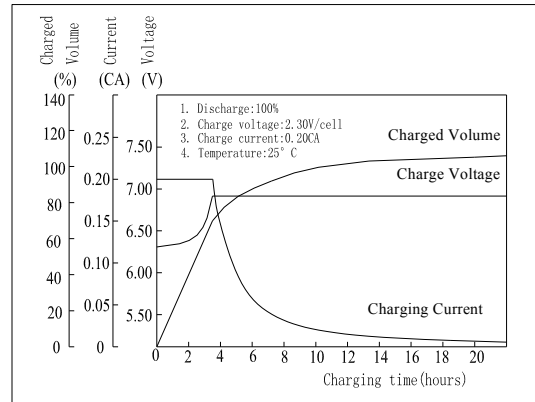

Cycle Life(25°C)

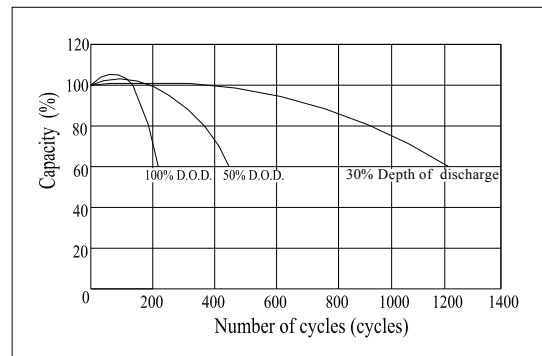

Note: Floating life at 20°C designed for 3 to 5 years.

- ◆ Absorbent glass mat technology;
- ◆ Recognized by UL & CE;
- ◆ ABS container.

Constant Current Discharge Characteristics (A, 25°C)

F.V/TIME	5min	10min	15min	30min	60min	3h	5h	10h	20h
4.80V	4.00	2.50	2.20	1.10	0.66	0.24	0.16	0.09	0.05
5.10V	3.80	2.38	1.92	1.06	0.63	0.24	0.16	0.09	0.05
5.40V	3.57	2.23	1.82	1.00	0.60	0.24	0.16	0.09	0.05

Constant Power Discharge Characteristics (Watt, 25°C)

F.V/TIME	5min	10min	15min	30min	60min	3h	5h	10h	20h
4.80V	22.3	14.1	11.4	6.30	3.82	1.45	0.97	0.55	0.30
5.10V	21.2	13.4	10.9	6.05	3.67	1.43	0.96	0.54	0.30
5.40V	19.9	12.6	10.4	5.75	3.49	1.40	0.94	0.54	0.30